

- A: Reach from swing center
- B: Bucket hook height
- C: Lifting capacity
- Cf: Rating over front
- Cs: Rating over side
- ⊕: Rating at maximum reach

PC78US-8		Arm : 1650mm 5'5"		Bucket : 0.28 m³ 0.37 yd³ SAE heaped		Shoe width : 450mm 17.7" triple grouser		Without blade		Unit : kg lb	
B	A	⊕ Maximum		4.5m 14'		3.0m 9'		1.5m 4'			
		Cf	Cs	Cf	Cs	Cf	Cs	Cf	Cs		
5.0m	16'	*1780	1430			*1790	*1790				
		*3920	3150			*3960	*3960				
3.0m	9'	1160	860	1500	1130	*2300	2280				
		2550	1910	3320	2500	*5070	5030				
0.0m	0'	1050	760	1370	1000	2650	1900				
		2310	1690	3020	2220	5850	4200				
-2.0m	-6'	1440	1050	1360	1000	*2630	1890	*4060	*4060		
		3170	2330	3010	2210	*5810	4180	*8960	*8960		

PC78US-8		Arm : 2250mm 7'5"		Bucket : 0.20 m³ 0.26 yd³ SAE heaped		Shoe width : 450mm 17.7" triple grouser		Without blade		Unit : kg lb	
B	A	⊕ Maximum		4.5m 14'		3.0m 9'		1.5m 4'			
		Cf	Cs	Cf	Cs	Cf	Cs	Cf	Cs		
5.0m	16'	*1420	1090	*1490	1200						
		*3140	2420	*3290	2650						
3.0m	9'	980	720	1540	1170	*1870	*1870				
		2160	1600	3400	2580	*4130	*4130				
0.0m	0'	880	640	1370	1000	2660	1920				
		1950	1410	3020	2220	5880	4230				
-2.0m	-6'	1120	820	1330	960	2590	1850	*4230	*4230		
		2490	1810	2930	2130	5710	4070	*9330	*9330		

* Load is limited by hydraulic capacity rather than tipping. Ratings are based on SAE Standard No. J1097. Rated loads do not exceed 87% of hydraulic lift capacity or 75% of tipping load.

PC78US-8		Arm : 1650mm 5'5"		Bucket : 0.28 m³ 0.37 yd³ SAE heaped		Shoe width : 450mm 17.7" triple grouser		Blade on ground		Unit : kg lb	
B	A	⊕ Maximum		4.5m 14'		3.0m 9'		1.5m 4'			
		Cf	Cs	Cf	Cs	Cf	Cs	Cf	Cs		
5.0m	16'	*1780	1500			*1790	*1790				
		*3920	3310			*3960	*3960				
3.0m	9'	*1670	910	*1780	1190	*2300	*2300				
		*3680	2020	*3930	2640	*5070	*5070				
0.0m	0'	*1710	810	*2120	1060	*3360	2010				
		*3770	1800	*4680	2350	*7410	4430				
-2.0m	-6'	*1650	1120	*1510	1060	*2710	2000	*4060	*4060		
		*3650	2460	*3330	2340	*5980	4410	*8960	*8960		

PC78US-8		Arm : 2250mm 7'5"		Bucket : 0.20 m³ 0.26 yd³ SAE heaped		Shoe width : 450mm 17.7" triple grouser		Blade on ground		Unit : kg lb	
B	A	⊕ Maximum		4.5m 14'		3.0m 9'		1.5m 4'			
		Cf	Cs	Cf	Cs	Cf	Cs	Cf	Cs		
5.0m	16'	*1420	1150	*1490	1260						
		*3140	2540	*3290	2780						
3.0m	9'	*1350	770	*1570	1230	*1870	*1870				
		*2990	1700	*3470	2710	*4130	*4130				
0.0m	0'	*1520	680	*2090	1060	*3320	2020				
		*3360	1510	*4600	2350	*7330	4460				
-2.0m	-6'	*1540	870	*1880	1020	*3010	1950	*4230	*4230		
		*3400	1920	*4140	2260	*6640	4300	*9330	*9330		

* Load is limited by hydraulic capacity rather than tipping. Ratings are based on SAE Standard No. J1097. Rated loads do not exceed 87% of hydraulic lift capacity or 75% of tipping load.

www.Komatsu.com

Printed in Japan 200810 IP.As(10)



CEN00339-00

Materials and specifications are subject to change without notice.
KOMATSU is a trademark of Komatsu Ltd. Japan.

KOMATSU®

PC78US-8

HORSEPOWER
Gross: 42.8 kW 57 HP @ 1950 rpm
Net: 41 kW 55 HP @ 1950 rpm

OPERATING WEIGHT
6945–7535 kg 15,315–16,615 lb

BUCKET CAPACITY
0.09–0.34 m³ 0.12–0.45 yd³



PC
78us



Photo may include optional equipment.

COMPACT
 HYDRAULIC EXCAVATOR

WALK-AROUND

Ecology and Economy Features

● Low emission engine

A powerful, turbocharged and air-to-air aftercooled Komatsu SAA4D95LE-5 provides **41 kW** 55 HP. This engine is EPA Interim Tier 4 and EU Stage 3A emissions certified without sacrificing power or machine productivity.

● Low operation noise

See page 4.

Productivity Features

● Tight tail swing

- Excellent operation in tight tail swing radius design
Tail swing radius: 1240 mm 4'1"

● High mobility

- Large drawbar pull and steering force are evident when operating on a slope or other rough terrain.
Max. drawbar pull:
66.9 kN 6820 kgf 15,050 lb
- The machine travel speed changes automatically to Hi or Lo at optimal points according to the travel load.

● Mode selection

- Five working modes designed to match engine speed, pump delivery and system pressure.
- Economy mode improves fuel consumption.
- Eco-gauge for energy-saving operations
- Extended idling caution for fuel conservation

See page 5.

Safety Features

- Cab dedicated to hydraulic excavator for protecting the operator in the event of a roll over accident.
- Safety enhancement with large side-view and rear-view mirrors.

See page 7.

Large Comfortable Cab

- Low noise design cab
 - Sliding convex door facilitates easy entrance in confined areas.
 - Large cab improves working space.
- See page 6.

Large TFT LCD Monitor

- Easy-to-see and use 7" large multi-function color monitor
- Can be displayed in 12 languages for global support.

TFT : Thin Film Transistor
LCD : Liquid Crystal Display

See page 9.



Easy Maintenance

- Side-by-side cooling function enables only the cooling unit to be attached and detached.
- Easy access to engine oil filter, engine main fuel filter and fuel drain valve
- Equipped with the fuel pre-filter (with water separator)
- Equipped with the Equipment Management Monitoring System (EMMS) monitoring system.

See page 8.



Photo may include optional equipment.

HORSEPOWER
Gross: 42.8 kW 57 HP @ 1950 rpm
Net: 41 kW 55 HP @ 1950 rpm

OPERATING WEIGHT
6945 – 7535 kg
15,315 – 16,615 lb

BUCKET CAPACITY
0.09 – 0.34 m³
0.12 – 0.45 yd³

PRODUCTIVITY & ECOLOGY FEATURES

Komatsu Technology



Komatsu develops and produces all major components in house such as engines, electronics and hydraulic components. Combining "Komatsu Technology", and customer feedback, Komatsu is achieving great advancements in technology.

To achieve both high levels of productivity and economical performance, Komatsu has developed the main components with a total control system. The result is a new generation of high performance and environment-friendly excavators.

Low Emission Engine

Komatsu SAA4D95LE-5 is EPA Interim Tier 4 and EU Stage 3A emissions certified.

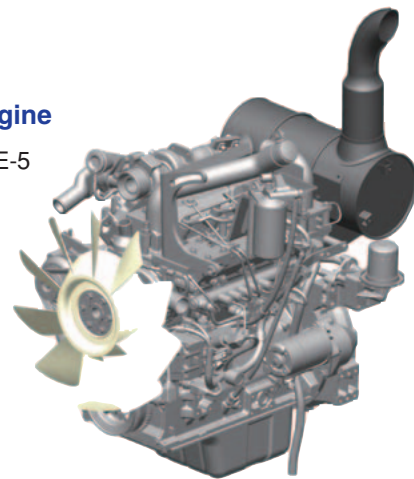

Low Operation Noise

Enables low noise operation using the low-noise engine and methods to cut noise at source.

Electronically controlled common rail type engine

- Multi-staged injection

Low noise design

- Optimal arrangement of sound absorbing materials
- Partition between the cab and engine room

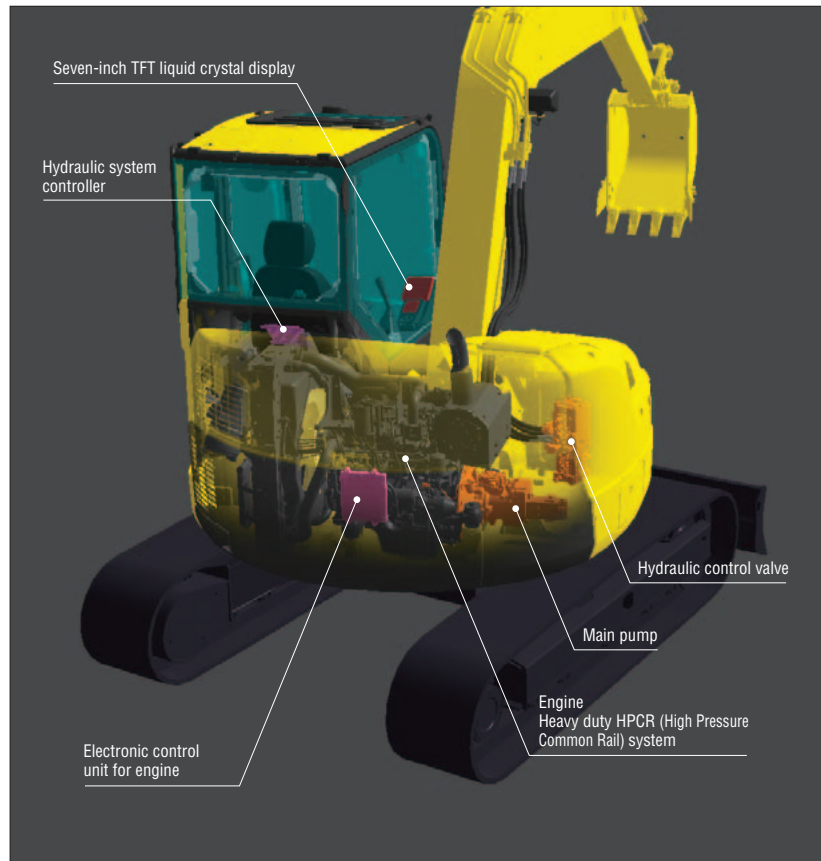

Photo may include optional equipment.

Advantage even in Confined Job Site

Tight Tail Swing

The narrow swing area is well suited for operation in confined areas with only a 80mm (3.1") protrusion over the tracks.

Road & bridge work

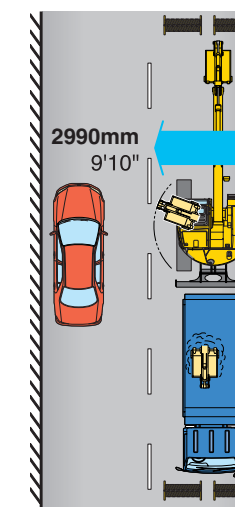

Short swing radius

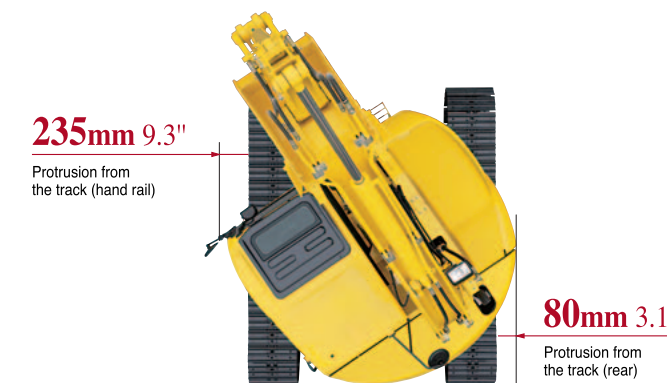
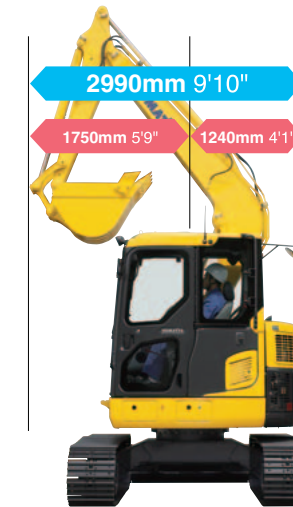

High Mobility

The PC78US-8 exceptional travel performance is provided by large drawbar pull and single pump with double flow, and it demonstrates superb maneuverability while operating at its optimum travel speed. It exhibits a large drawbar pull for moving on job sites, traveling in rough terrain and climbing steep slopes.

Maximum drawbar pull: 66.9 kN 6820 kgf 15050 lb

Auto-decel

Engine speed automatically slows down when all control levers are set in neutral to minimize fuel consumption.

Two Automatic Travel Speeds

High or low—whichever speed suits the ground and job conditions—can be selected with one touch. As terrain changes, travel speed will automatically shift up or down within the selected speed range.

Working Modes Selectable

The PC78US-8 excavator is equipped with five working modes (P, E, L, B and ATT mode). Each mode is designed to match engine speed and pump speed with the current application. This provides the flexibility to match equipment performance to the job at hand.

Working Mode	Application	Advantage
P	Power mode	<ul style="list-style-type: none"> • Maximum production/power • Fast cycle times
E	Economy mode	<ul style="list-style-type: none"> • Good cycle times • Better fuel economy
L	Lifting mode	<ul style="list-style-type: none"> • Engine rpm reduction
B	Breaker mode	<ul style="list-style-type: none"> • Optimum engine rpm, hydraulic flow
ATT	Attachment mode	<ul style="list-style-type: none"> • Optimum engine rpm, hydraulic flow, 2way

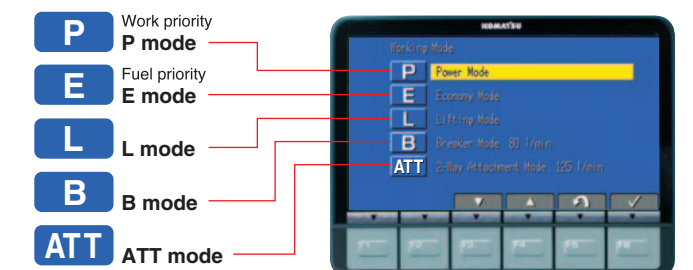

Eco-gauge that Assists Energy-saving Operations

The Eco-gauge on the right side of the multi-function color monitor provides environment-friendly energy-saving operation. Allows focus on operation in the green range with reduced CO₂ emissions and efficient fuel consumption.



Eco-gauge

Idling Caution

To prevent unnecessary fuel consumption, an idling caution is displayed on the monitor, if the engine idles for 5 minutes or more.



WORKING ENVIRONMENT

Large Comfortable Cab



Photo : Rigid seat

Multi-position Controls

The multi-position, PPC (pressure proportional control) levers allow the operator to work in comfort while maintaining precise control. A double-slide mechanism allows the seat and controllers to move together or independently, allowing the operator to position the seat and controllers for maximum productivity and comfort.

Low Cab Noise

Cab is highly rigid and has excellent sound absorption ability. Thorough improvement of noise source reduction and use of low noise engine, hydraulic equipment, and air conditioner allows this machine to generate a low level of noise.

Large Cab

Large cab provides ample operation space. The cab has wide doorway for easy access.



Photo : Rigid seat

Automatic Air Conditioner

Automatic air conditioner is utilized. The bi-level control function keeps the operator's head and feet cool and warm respectively. This improved air flow function keeps the inside of the cab comfortable throughout the year. Defroster function keeps cab glass clear.



Sliding Convex Door

The sliding convex door facilitates easy entrance in confined areas.



Safety Features

New Cab Design for Hydraulic Excavators

The cab is designed specifically for hydraulic excavators and gains reinforced strength from the pipe-structured cab framework. The cab framework provides the high durability and impact resistance with very high impact absorbency. The seat belt keeps the operator in the seat of the cab in the event of a roll over.

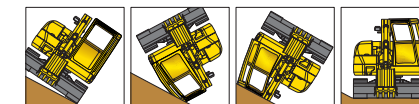
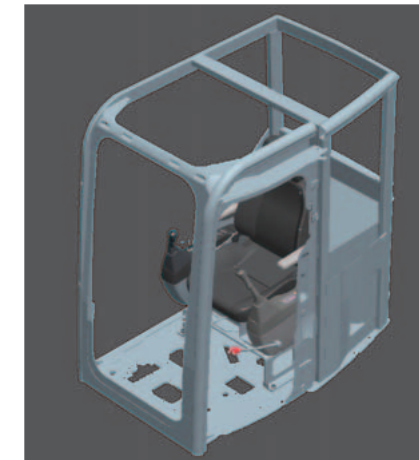

Wide Visibility

Large cab and extended front glass enable operator to get better visibility.



Lock Lever

When lock lever is placed in lock position all hydraulic controls (travel, swing, boom, arm, bucket and blade) are inoperable.



Lever shown in lock position

Retractable Seat Belt

Easy-to-use retractable seat belt is employed.

Emergency Escape Hammer

The cab is equipped with an emergency escape hammer for breaking the rear window glass in case of an emergency.



Thermal and Fan Guards

Thermal and fan guards are placed around high-temperature parts of the engine and fan drive.



Side-view and Rear-view Mirrors

Large side mirror and rear mirror allow the PC78US-8 to meet the new ISO visibility requirements.



Travel Alarm

An alarm is installed as standard equipment to give other workers a warning when the machine travels in forward or reverse.

Skylight

Skylight with window can be opened for overhead visibility.



MAINTENANCE FEATURES

Easy Maintenance

Komatsu designed the PC78US-8 to have easy service access. By doing so, routine maintenance and servicing are less likely to be skipped, which can mean a reduction in costly downtime later on. Here are some of the many service features found on the PC78US-8.

Optimum Maintenance Layout

With the engine hood, right side hood and side service doors, it is possible to access the major maintenance points from ground level. Furthermore, the fuel drain valve, engine oil filter and swing machinery oil filler are remote mounted, facilitating easy maintenance.

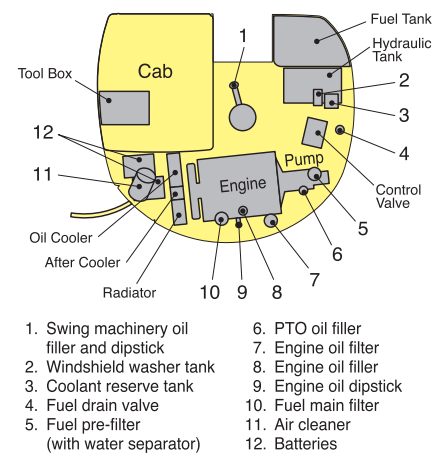

Side-by-side Cooling

Since radiator, aftercooler and oil cooler are arranged in parallel, it is easy to clean, remove and install them. Radiator, aftercooler, and oil cooler made of aluminum have high cooling efficiency and are easily recycled.



Easy Access to Engine Oil Filter, Engine Main Fuel Filter and Fuel Drain Valve

Engine oil filter, engine main fuel filter and fuel drain valve are remote mounted to improve accessibility.



Equipped with the Fuel Pre-filter (with Water Separator)

Removes water and contaminants in the fuel to prevent fuel problems. (with built-in priming pump)



Air Conditioner Filter

The air conditioner filter is removed and installed without the use of tools facilitating filter maintenance.



External air conditioner filter



Internal air conditioner filter

Long Greasing Interval

All bushing lubrication intervals of work equipment except arm top bushings are 500 hours, reducing maintenance cost.

Large TFT LCD Monitor

Large Multi-lingual LCD Monitor

A large user-friendly color monitor enables safe, accurate and smooth work. Improved screen visibility is achieved by the use of TFT liquid crystal display that can easily be read at various angles and lighting conditions. Simple and easy to operate switches. Industry first function keys facilitate multi-function operations. Displays data in 12 languages to globally support operators around the world.



Indicators

- 1 Auto-decelerator
- 2 Working mode
- 3 Travel speed
- 4 Engine water temperature gauge
- 5 Hydraulic oil temperature gauge
- 6 Fuel gauge
- 7 Eco-gauge
- 8 Function switches menu

Basic operation switches

- 1 Auto-decelerator
- 2 Working mode selector
- 3 Traveling selector
- 4 Buzzer cancel
- 5 Wiper
- 6 Windshield washer

Function switches

Basic operation switches

Air conditioner operation switches

EMMS (Equipment Management Monitoring System)

Monitor function

Controller monitors engine oil pressure, coolant temperature and battery charge etc. If controller finds any abnormality, it is displayed on the LCD.



Maintenance function

Monitor informs replacement time of oil and filters on LCD when the replacement interval is reached.



Trouble data memory function

Monitor stores abnormalities for effective troubleshooting.

Option

Roadliner

Ideal performance has been achieved with combining the merits of rubber and the strengths of steel in the new Road Liner shoes.



Blade

Back fill blade can quickly and conveniently fill trenches and clear up jobsites.



Photo : Bolt-on cutting edge type

Additional Counter Weight

Additional weight is designed for increased lift capacity and easy installation.



SPECIFICATIONS

ENGINE

Model Komatsu SAA4D95LE-5
 Type Water-cooled, 4-cycle
 Aspiration Turbocharged, and air-to-air aftercooled
 Number of cylinders 4
 Bore x stroke 95 mm x 115 mm 3.74" x 4.53"
 Piston displacement 3.26 ltr 199 in³
 Governor All-speed control, electronic
 Horsepower
 SAE J1995 Gross 42.8 kW 57 HP
 ISO 9249 / SAE J1349 Net 41 kW 55 HP
 Rated rpm 1950 rpm
 Fuel system Direct injection
 Lubrication system
 Method Gear pump, force-lubrication
 Filter Full-flow
 Air cleaner Dry-type with double elements
 and auto dust evacuator, plus dust indicator
 EPA Interim Tier 4 and EU Stage 3A emissions certified
 Starting motor 4.5 kW/24 V
 Alternator 35 A/24 V
 Battery 55 Ah/2 x 12 V

HYDRAULICS SYSTEM

Type HydraMind (Hydraulic Mechanical Intelligence New Design) system, Closed-center system with load-sensing valve and pressure-compensated valve

Main pumps:
 Type Variable displacement, axial piston
 Maximum flow 160 ltr/min 42.3 U.S. gal/min
 Type (for machine with blade) Fixed displacement gear
 Maximum flow 63 ltr/min 16.6 U.S. gal/min

Hydraulic motors:
 Travel 2 x piston motor with parking brake
 Swing 1 x piston motor with swing holding brake

Relief valve setting:
 Implement, travel circuit 26.5 MPa 270 kgf/cm² 3,840 psi
 Swing circuit 20.6 MPa 210 kgf/cm² 2,990 psi
 Blade circuit (Raise) 12.7 MPa 130 kgf/cm² 1,850 psi
 (Lower) 21.1 MPa 215 kgf/cm² 3,060 psi

Hydraulic cylinders:
 (Number of cylinders – bore x stroke x rod diameter)
 Boom 1–115 mm x 858 mm x 65 mm 4.5" x 33.8" x 2.6"
 Arm 1–100 mm x 861 mm x 60 mm 3.9" x 33.9" x 2.4"
 Bucket 1– 90 mm x 710 mm x 55 mm 3.5" x 28.0" x 2.2"
 Blade 1–130 mm x 130 mm x 65 mm 5.1" x 5.1" x 2.6"

STANDARD EQUIPMENT

- Air cleaner, double element with auto dust evacuator
- Alternator, 35Ampere, 24V
- Automatic air conditioner
- Auto deceleration
- Batteries, 55Ah/2 x 12V
- Cab which includes: floor mat, intermittent front windshield wiper and washer, large ceiling hatch, pull-up front window, removable lower windshield
- Cooling fan, suction type
- Monitor panel
- Rear view mirrors (LH, rear)
- Seat belt 50mm 2"
- Shoes, —450mm 17.7" Triple grouser
- Starting motor 4.5kW
- Suspension seat
- Travel alarm
- Working lights —1 on cab —1 on boom

SWING SYSTEM

Driven by Hydraulic motor
 Swing reduction Planetary gear
 Swing circle lubrication Grease-bathed
 Swing lock Mechanical disc brake
 Swing speed 10 rpm

DRIVES AND BRAKES

Steering control Two levers with pedals
 Drive method Hydrostatic
 Maximum drawbar pull 66.9 kN 6820 kgf 15,050 lbf
 Maximum travel speed: High 5.0 km/h 3.1 mph
 Low 2.9 km/h 1.8 mph
 Service brake Hydraulic lock
 Parking brake Mechanical disc

UNDERCARRIAGE

Center frame X-frame
 Track frame Box-section
 Seal of track Sealed track
 Track adjuster Hydraulic
 Number of shoes 39 each side
 Number of carrier rollers 1 each side
 Number of track rollers 5 each side

COOLANT AND LUBRICANT CAPACITY (REFILLING)

Fuel tank 125 ltr 33.0 U.S. gal
 Radiator 10 ltr 2.6 U.S. gal
 Engine 11.5 (11.0) ltr 3.0 (2.9) U.S. gal
 Final drive, each side 1.1 ltr 0.3 U.S. gal
 Swing drive 2.0 ltr 0.5 U.S. gal
 Hydraulic tank 100 (56) ltr 26.4 (14.8) U.S. gal

OPERATING WEIGHT (APPROXIMATE)

Operating weight including 3710 mm 12'2" one-piece boom, 1650 mm 5'5" arm, SAE heaped 0.28 m³ 0.37 yd³ backhoe bucket, blade, rated capacity of lubricants, coolant, full fuel tank, operator, and standard equipment.

	Shoes		Operating Weight		Ground Pressure		
	mm	in	kg	lb	kPa	kg/cm ²	psi
With blade	450	17.7"	7365	16,240	33.0	0.34	4.83
	600	23.6"	7535	16,615	25.3	0.26	3.70
without blade	450	17.7"	6945	15,315	31.1	0.32	4.51
	600	23.6"	7115	15,690	23.9	0.24	3.47

DIMENSIONS

Boom Length	3710 mm 12'2"	3710 mm 12'2"
Arm Length	1650 mm 5'5"	2250 mm 7'5"
A Overall length	5770 mm 18'11"	6295 mm 20'8"
B Overall height (to top of boom)*	2555 mm 8'5"	2870 mm 9'5"

C Overall width	2330 mm 7'8"
D Overall height (to top of cab)*	2730 mm 8'11"
E Ground clearance, counterweight	735 mm 2'5"
F Minimum ground clearance	360 mm 1'2"
G Tail swing radius	1240 mm 4'1"
H Length of track on ground	2235 mm 7'4"
I Track length	2840 mm 9'4"
J Track gauge	1870 mm 6'2"
K Width of crawler	2320 mm 7'7"
L Shoe width	450 mm 17.7"
M Grouser height	20 mm 0.8"
N Machine cab height	1835 mm 6'0"
O Machine cab width	2330 mm 7'8"
P Distance swing center to rear end	1405 mm 4'7"

*: Including grouser height

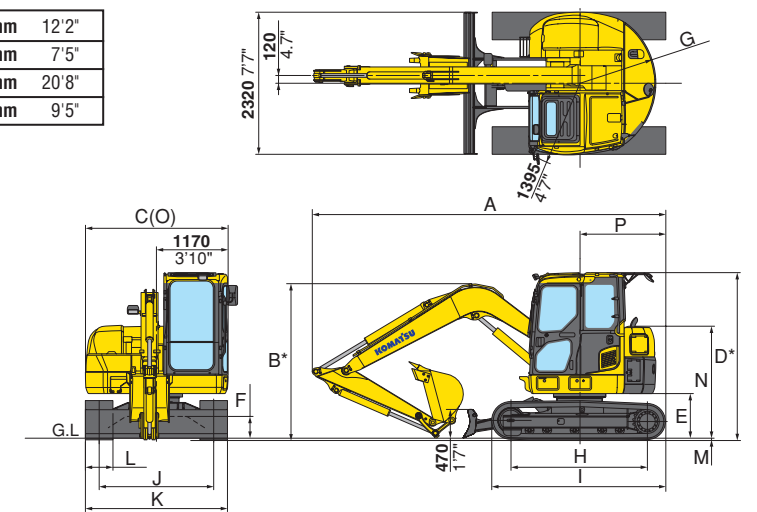

WORKING RANGE

Boom Length	3710 mm 12'2"	3710 mm 12'2"
Arm Length	1650 mm 5'5"	2250 mm 7'5"
A Maximum digging height	7300 mm 23'11"	7600 mm 24'11"
B Maximum dumping height	5180 mm 17'0"	5500 mm 18'1"
C Maximum digging depth	4100 mm 13'5"	4710 mm 15'5"
D Maximum vertical wall digging depth	3610 mm 11'10"	4030 mm 13'3"
E Maximum digging depth of cut for 2440 mm 8' level	3770 mm 12'4"	4430 mm 14'6"
F Maximum digging reach	6380 mm 20'11"	6920 mm 22'8"
G Maximum digging reach at ground	6240 mm 20'6"	6790 mm 22'3"
H Minimum digging reach at ground	1900 mm 6'3"	1735 mm 5'8"
I Minimum swing radius	1750 mm 5'9"	2050 mm 6'9"
ISO Bucket digging force	61.3 kN 6250 kgf 13,780 lbf	61.3 kN 6250 kgf 13,780 lbf
Arm crowd force	41.5 kN 4230 kgf 9,330 lbf	34.5 kN 3520 kgf 7,760 lbf
SAE Bucket digging force	53.3 kN 5440 kgf 11,990 lbf	53.3 kN 5440 kgf 11,990 lbf
Arm crowd force	38.1 kN 3890 kgf 8,570 lbf	33.1 kN 3380 kgf 7,450 lbf

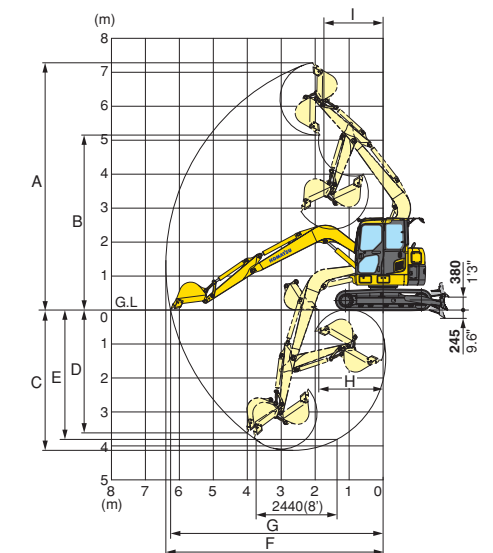

BACKHOE BUCKET AND ARM COMBINATION

Bucket Capacity (heaped)		Width		Weight	Number of Teeth	Arm Length	
SAE, PCSA	CECE	Without Side Cutters	With Side Cutters			1650 mm 5'5"	2250 mm 7'5"
0.09 m ³ 0.12 yd ³	0.08 m ³ 0.10 yd ³	350 mm 14"	450 mm 18"	145 kg 320 lb	3	○	○
0.12 m ³ 0.16 yd ³	0.11 m ³ 0.14 yd ³	450 mm 18"	550 mm 22"	160 kg 355 lb	3	○	○
0.20 m ³ 0.26 yd ³	0.18 m ³ 0.24 yd ³	550 mm 22"	650 mm 26"	185 kg 410 lb	3	○	○
0.28 m ³ 0.37 yd ³	0.25 m ³ 0.33 yd ³	650 mm 26"	750 mm 30"	210 kg 465 lb	4	○	X
0.34 m ³ 0.45 yd ³	0.30 m ³ 0.39 yd ³	755 mm 29.7"	NA	210 kg 465 lb	4	□	X

○—General digging □—Light-duty operation X—Not available

OPTIONAL EQUIPMENT

- Additional counter weight —220 kg 485 lb
- Additional working light on cab
- Arm, —1650mm 5'5" arm assembly
- Blade
- Boom, —3710mm 12'2"
- Hydraulic control unit —1 additional actuator
- Long arm, —2250mm 7'5" arm assembly
- Reinforced blade with BOC
- Seat belt 78mm 3"
- Shoes, —450mm 17.7" Road Liner —600mm 23.6" Triple grouser —450mm 17.7" Rubber shoe